

COMPATIBLE MOTOR DIMENSIONS

A	B	C	D	E	F	H	L
≤ 24	110	≤ 57.5	≤ 9	145	8.1~10.0	110~130	≥ C-9.5

※BUSHING WILL BE SUPPLIED WHEN THE MOTOR SHAFT DIAMETER IS SMALLER THAN 24

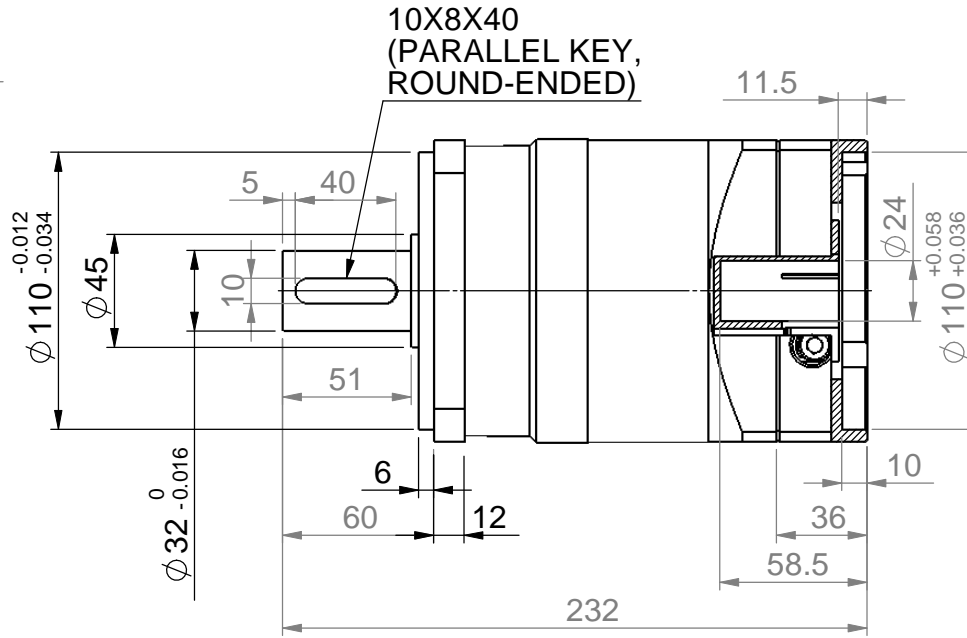
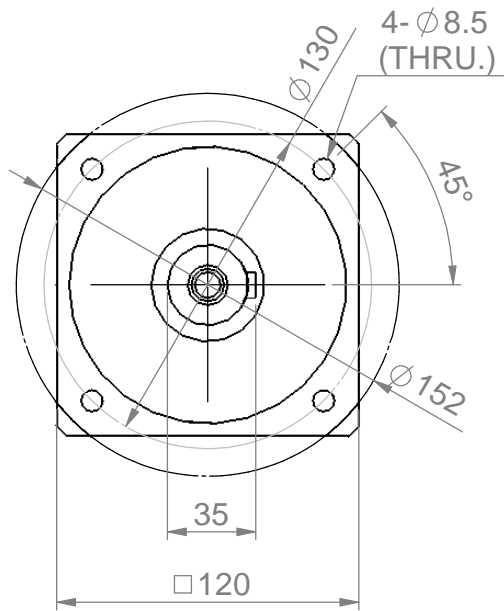

M8X20L
(SOCKET HEAD
CAP SCREW)

4 x M8x1.25 Px16 (DEPTH)

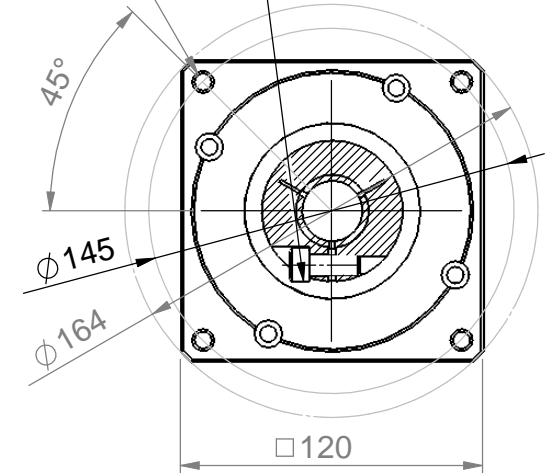

ADAPTER PART NO.
234B044313

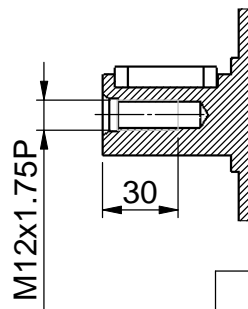

SPECIFICATIONS ARE SUBJECT TO
CHANGE WITHOUT PRIOR NOTICE

Unit	mm	Model Name	PGE/PEE120 2 STAGE
Project		Drawing No.	3D4XD.110120.142



SESAME MOTOR CORP.