

COMPATIBLE MOTOR DIMENSIONS

A	B	C	D	E	F	H	L
≤ 35	110	≤ 70.5	≤ 9	145	8.1~10.0	120~160	≥ C-9.5

※ BUSHING WILL BE SUPPLIED WHEN THE MOTOR SHAFT DIAMETER IS SMALLER THAN 35

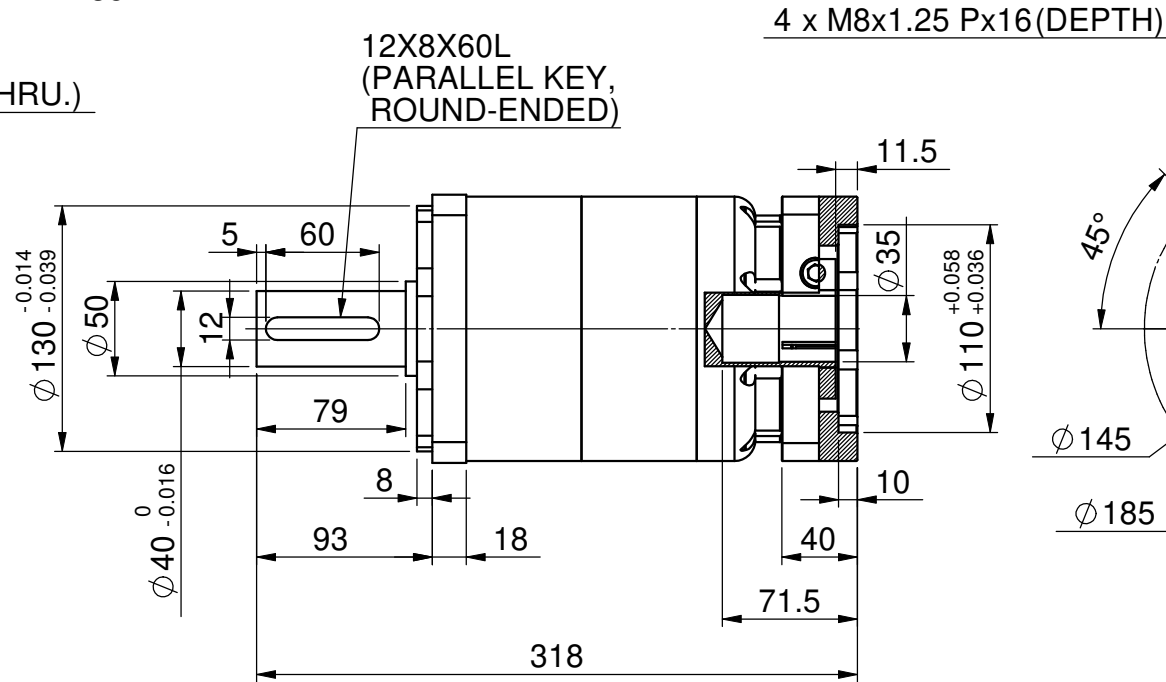
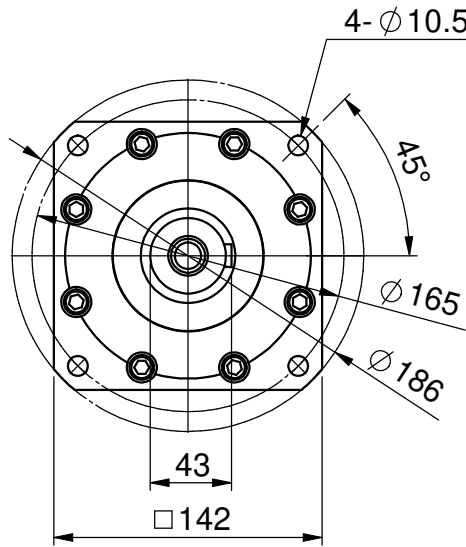

M10X25L  
(SOCKET HEAD  
CAP SCREW)

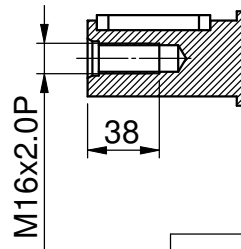
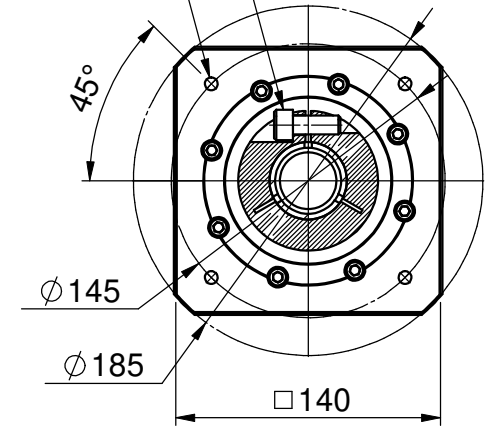

ADAPTER PART No.  
2341F56411

SPECIFICATIONS ARE SUBJECT TO  
CHANGE WITHOUT PRIOR NOTICE

Unit	mm	Model Name	PGL/PEL/PGE/PEE 142 2 STAGE
Project		Drawing No.	1A5XD.110140.142



SESAME MOTOR CORP.